

INSTALLATION INSTRUCTIONS

WALL-MOUNT Air Handler Unit

Fixed frequency 1.5-2-2.5-3Tons
R410A

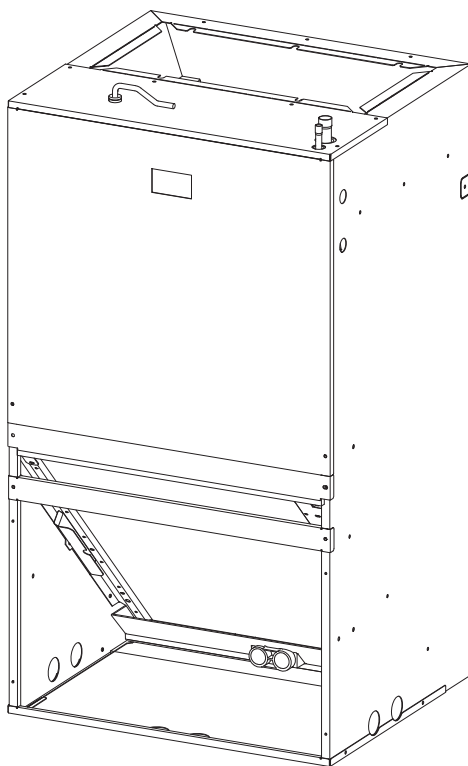

CONTENTS

1. Symbol and Key to Safety Instructions.....	01
2. Accessories	03
3. Installation Instructions.....	04
4. Electrical Wiring.....	09
5. Airflow Performance	12
6. Piping System	14
7. Refrigerant Pipe Connection	15
8. Air Filter (Not Factory Installed).....	17
9. Installation Size of Filter Screen.....	18
10. Maintenance.....	19
11. Wiring Diagram	20

1. Symbol and Key to Safety Instructions

1.1 Symbol Keywords



WARNING

The warnings in this document are identified by warning triangles printed on a gray background. The keyword at the beginning of the warning indicates the type and severity of the risk if no measures are taken to prevent it.

The following keywords are defined and used in this document:



Dangerous

means a Hazardous situation, which, if not avoided, will lead to death or serious injury.



Warning

Indicates a Hazardous situation, which may lead to death or serious injury if not avoided.



Caution

Indicates a Hazardous situation, which may cause mild to moderate injury if not avoided.



Note

Used to deal with behaviors unrelated to personal injury.

Important Information



This symbol represents important information that is not harmful to people or property.

1.2 Safety

Please Read Before Continuing.

Warning:

- The unit must be installed by qualified personnel with a capacity certificated for handling refrigerant fluids. Refer to regulation and laws in use on installation location.
- This appliance is not intended for use by persons (including children) with reduced physical, sensory or mental capabilities, or lack of experience and knowledge, unless they have been given supervision or instruction concerning use of the appliance by a person responsible for their safety.
- The appliance shall be installed in accordance with national wiring regulations.
- Children should be supervised to ensure that they do not play with the appliance.
- The minimum clearance to combustible surfaces (curtains, blinds, etc.) from the appliance should be 300 mm.
- Before accessing the connection terminals, all power circuits must be disconnected.
- Please read these instructions carefully before attempting to install or operate. Failure to follow these instructions may result in incorrect installation, adjustment, repair or maintenance, which may result in fire, electric shock, property damage, personal injury or death.



This document is property of customer and should be kept together with this equipment. These instructions do not cover all the different variations of the system, nor do they provide all the unexpected situations that may be encountered during the installation process.



Warning: Fire, electric shock, property damage, personal injury or death

- The whole installation process must comply with NATIONAL, STATE AND LOCAL CODES. If you need more information, please contact your local dealer.
-



Warning: Risk of electric shock

- Can cause injury or death, disconnect all remote electric power. More than one disconnect switch may be required to cut off the power of the equipment. Dangerous voltage can cause serious personal injury or death.
-



Warning: Electric shock

- If the fan assembly needs to be dismantled, all disconnect switches supplying power to the equipment must be powered off and locked (if the device cannot be seen), so that the field power cord can be safely dismantled from the fan assembly. Otherwise, it may cause electric shock, personal injury or death.
-



Warning: Fire, electric shock, property damage, personal injury or death

- Due to possible equipment damage or personal injury, installation, repair and maintenance should be carried out by trained qualified maintenance personnel. Consumers are advised to only clean/replace the filter screen. Do not operate the equipment with the access panel removed.
-



Warning:

- This product may expose you to chemicals including lead and lead components, which are known to cause cancer, birth defects or other reproductive harm in California. For more information, please visit www.P65Warnings.ca.gov.
-



Warning: Electric shock

- The device must be permanently grounded. Otherwise, it will cause electric shock, personal injury or death.
-



Note: Fire risk

- The materials of pressure ventilation system and piping system must meet the latest NFPA 90B standard.
-



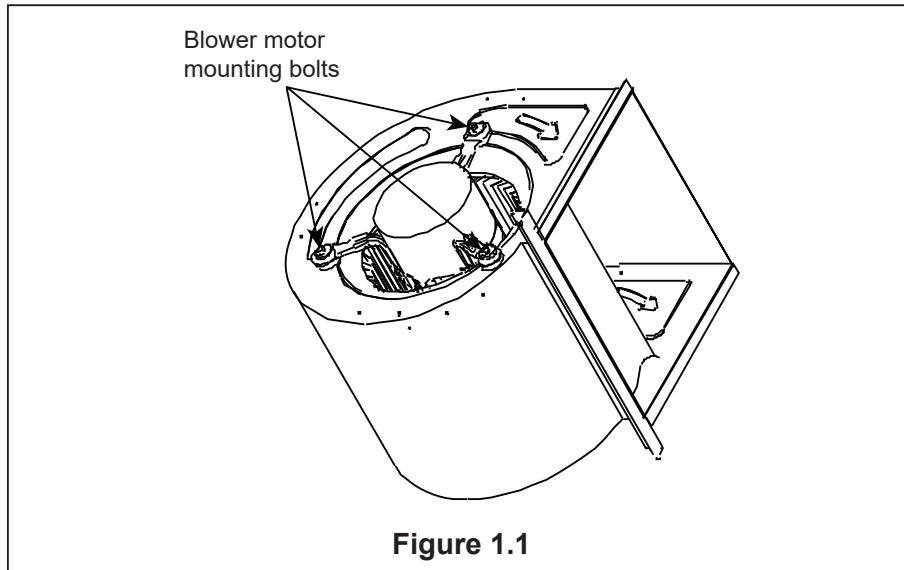

Note:

- Make sure the fan bracket is fastened (3motor mounting bolts-Figure1). Then, before operating the device, check whether the wheels are firmly fixed on the motor shaft.
-

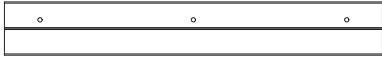
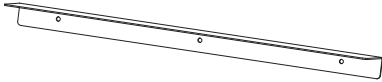

2. Accessories

Name	Quantity	Shape
INSTALLATION INSTRUCTIONS	1	
WALL MOUNT BRACKET	2	
WALL MOUNT BRACKET (ONLY FOR 30K/36K)	1	
DRAIN PLUG	1	
RUBBER GASKET	1	

3. Installation Instructions

3.1 Unpacking

Carefully unpack the unit and inspect the contents for damage. If any damage is found at the time of delivery, proper notification and claims should be made with the carrier.

Check the rating plate to assure model number and voltage. Furthermore, check that kits match with what was ordered. The manufacturer should be notified within 5 days of any discrepancy or parts shortage.

3.2 Location

The small air handler should be centrally located and may be installed in a closet, alcove, utility room, or basement. Minimum clearances must be met. The air handler comes standard with two different options for mounting, wall mount or frame mount. Both mounting options require the unit to be level from side to side and from front to back in order to allow condensate to properly drain from the unit. Failure to do this will result in condensate leaking out from the unit, potentially causing structural damage to the surrounding support structures, dry wall, carpet, etc. Also, both mounting structures require the ability to accommodate a minimum of 150 lb load. Failure to do this will cause damage to the support structure and potentially damage the unit.

3.2.1 WALL MOUNT

The air handler comes standard with an upper and lower wall mount bracket. Reference Figure 3.1 for more detail.

1. Remove lower wall mounting bracket from the back of the unit by removing one screw which attaches the bracket to the air handler. Note: Discard the screw after you have removed the wall mounting bracket.

2. Install bracket on the wall by using 3 wood screws (not provided). Make sure the bracket is level in order to provide proper drainage from the unit. Note: Do not attach the wall mounting bracket into un-supported dry wall. Make sure that the wood screws are going into a structure that can support a minimum load of 150 lb.

3. Lift the air handler above the wall mounting bracket and attach the unit to the installed bracket. Reference Figure 3.1.

4. Install the additional bottom plate for extra support for this type mounting (see Figure 3. 1).

Note: The additional plate is shipped in the bottom of the shipping carton (only for 30/36k unit).

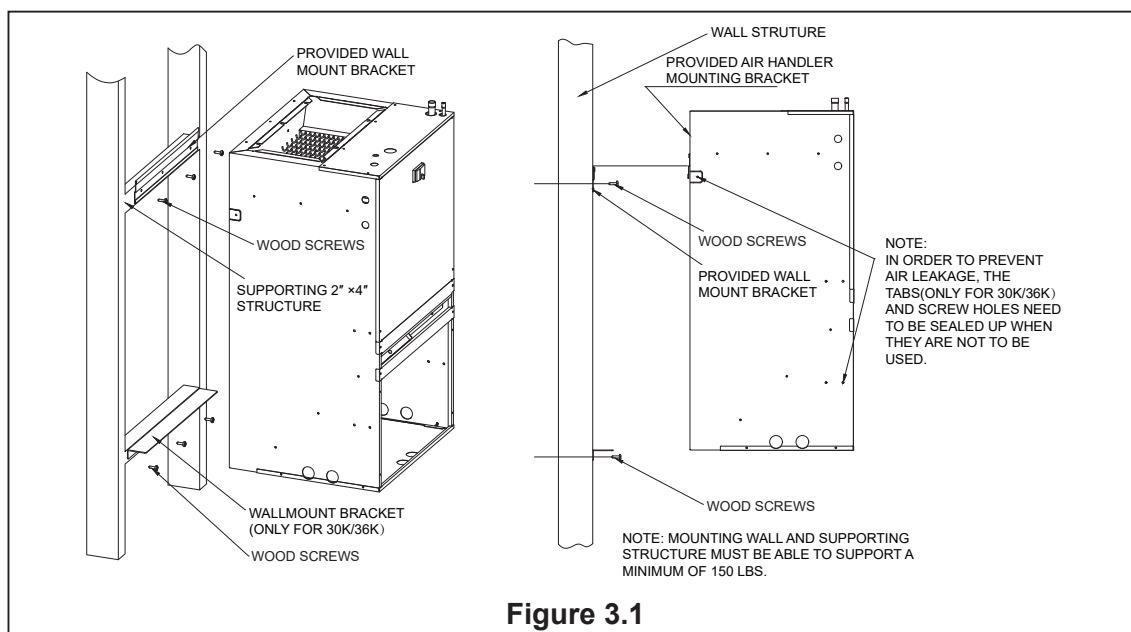

3.2.2 FRAME MOUNT

The air handler comes with 8 clearance holes (4 on each side). These holes are used to mount the air handler inside of a frame structure (see Figure 3.2). When mounting in this fashion, make sure that the wood screws are mounted from within the air handler and not outside of the unit. Install the screws from outside the unit, and avoid damaging the coil. If the frame does not provide support in the front of the unit and additional support is needed, open up the tabs and fix the unit to the frame or other support structure with screws (only for 30K/36K). Select a solid and level site to ensure proper installation of the frame mount. Verify that there is sufficient space for installation and maintenance. (See Figure 3.3)

IMPORTANT: The (8) wood screws are not provided with the unit.

#12 x 1 1/2" wood screws are recommended. When the unit is installed on a wood frame, the screws should be used to fix the unit to the studs. If they are not used, the unit may fall down or cause other damage. (See Figure 3.2) for frame mount installation.

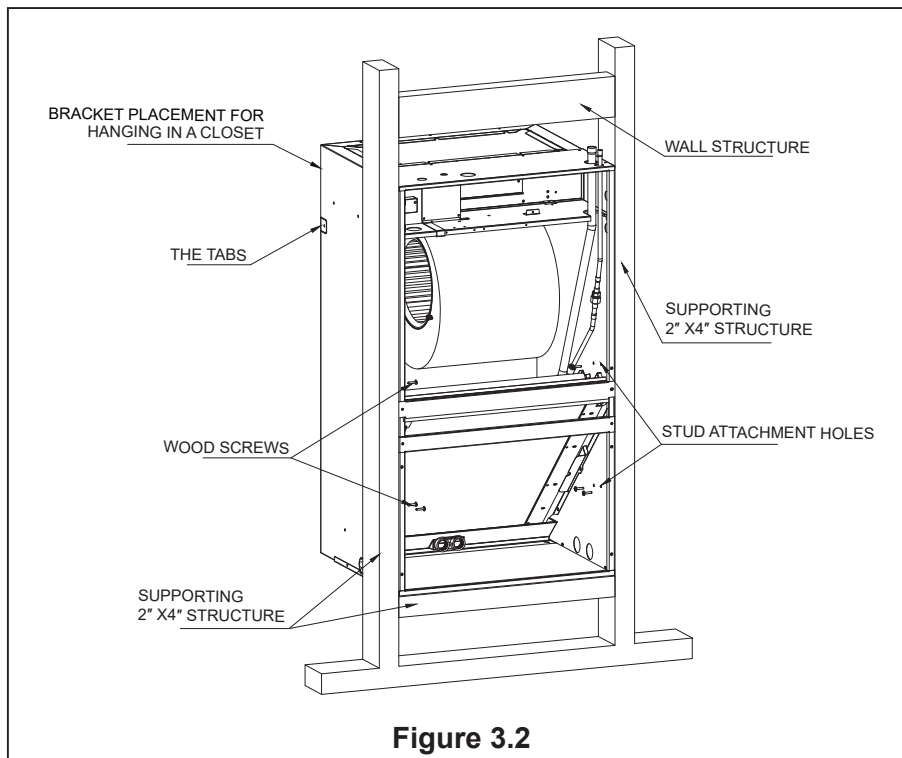

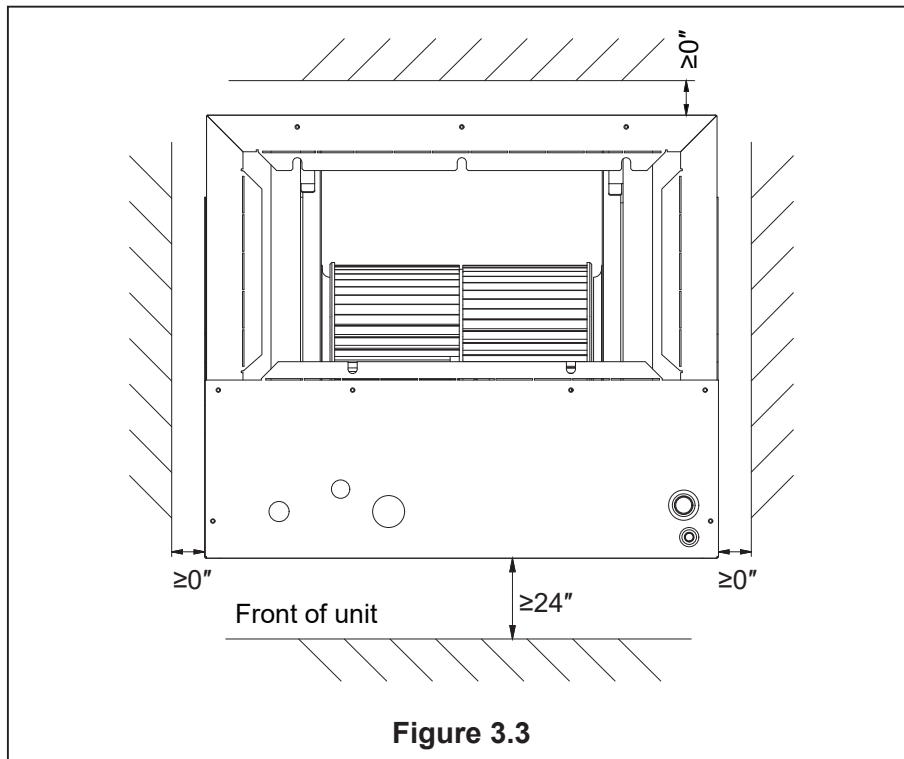

Warning: Note



- As shown in Figure 3.3, the installed device must have the required clearance. Failure to follow these instructions may result in equipment damage and/or premature equipment failure.
-

3.2.3 CONFIGURATIONS

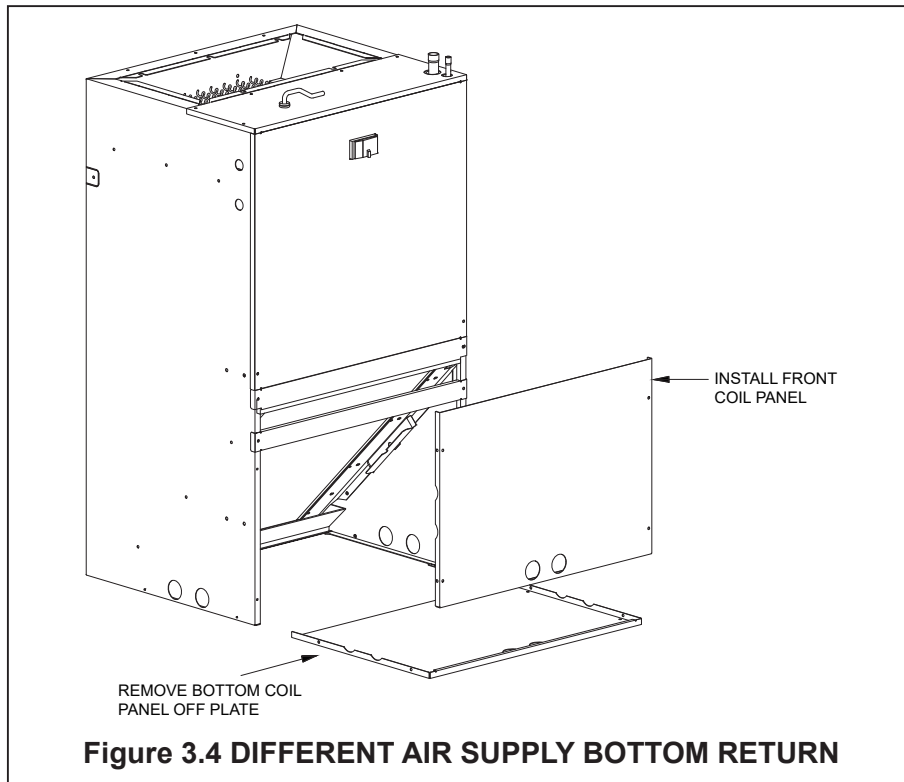

Conversion: Divert the return air from the factory standard front return to a bottom return. Remove the cross brace when converting cabinet to bottom return.

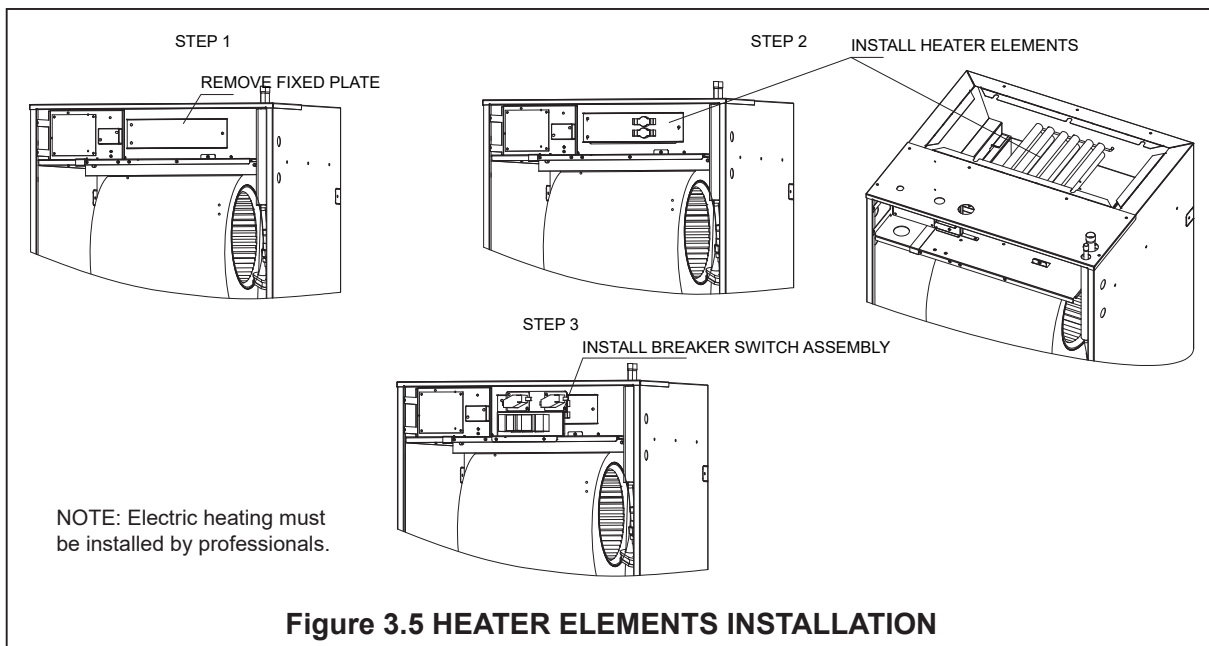

3.3 Installation in High Humidity Environment

When the unit is installed in a hot and humid place, if the temperature in the installation space exceeds 86 °F and the RH (relative humidity) exceeds 80%, it is recommended to insulate the outside of the cabinet. Use glass wool or polyethylene foam as insulation material; The thickness should be greater than 2 inches, and it must be suitable for the installation space opening. Condensate may also be produced on the insulation surface. Ensure that insulation materials designed for HVAC systems are used.

3.4 Unit Dimension

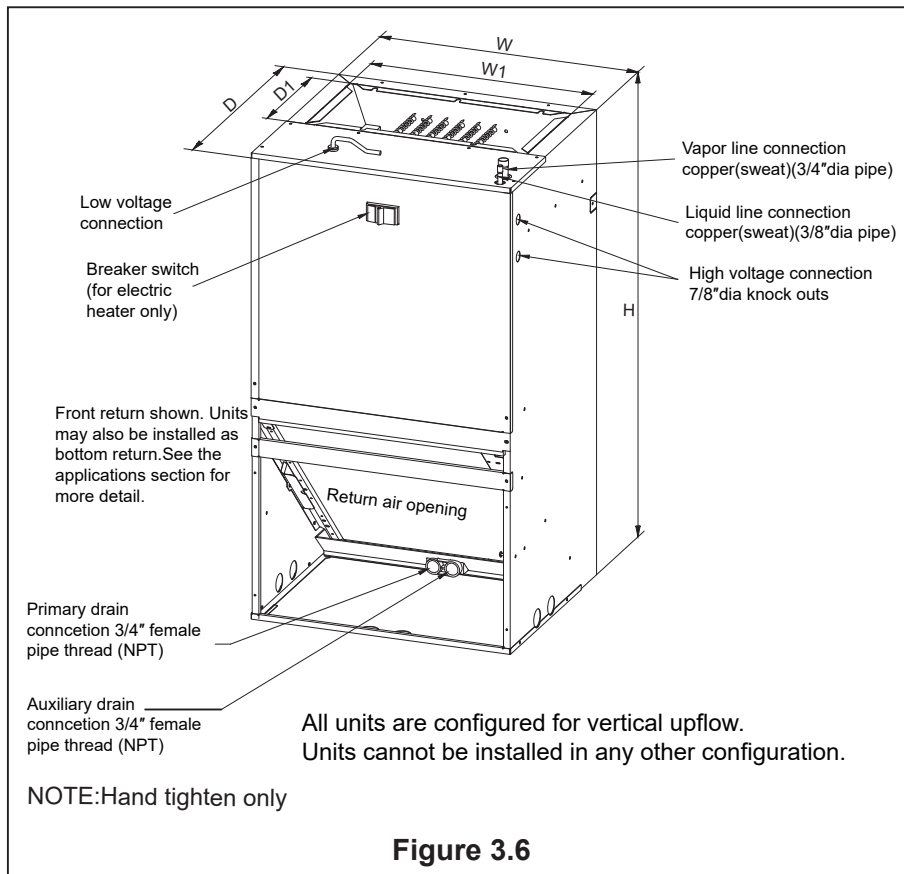

Table 3.1 Unit Dimension

Model Size	Dimensions inch (mm)					Unit Weight /Shipping Weight (LBS.(kg))
	Unit Height "H" inch (mm)	Unit Width "W" inch (mm)	Unit Width "W1" inch (mm)	Unit Length "D" inch (mm)	Unit Length "D1" inch (mm)	
18	36-1/2 (928)	20-2/3 (526)	17-1/2 (446)	15 (381)	9-1/2 (242)	81.4/91.3 (37)/(41.5)
24	36-1/2 (928)	20-2/3 (526)	17-1/2 (446)	15 (381)	9-1/2 (242)	81.4/91.3 (37)/(41.5)
30	39-1/2 (1004)	22 (559)	18-4/5 (478)	19 (483)	9-1/2 (242)	104.5/116.6 (47.5)/(53)
36	39-1/2 (1004)	22 (559)	18-4/5 (478)	19 (483)	9-1/2 (242)	104.5/116.6 (47.5)/(53)

4. Electrical Wiring

The wiring on site must comply with the National Electric Code (C.E.C. in Canada) and any applicable local regulations.



Warning: Electric shock

- Before installation or maintenance, please disconnect all power supply of the device. More than one disconnect switch may be required to cut off the power of the equipment. Dangerous voltage can cause serious personal injury or death.

4.1 Power Supply Wiring

It is important to have a suitable power supply connected to the device being installed. For more detailed requirements, please refer to the device rating label, wiring diagram and electrical data in the installation instructions.

- If necessary, install a branch circuit breaker of sufficient size, which is located within sight and easy to install.



When installing an electric heater, the device may be equipped with one or two 30-60 amp circuit breakers. These circuit breakers protect internal lines and act as disconnecting devices when short circuit occurs. The circuit breaker installed in the device does not provide overcurrent protection for the power connection, so its size may be larger than that of the branch circuit protection.

-
- The power supply line of the circuit must be a minimum 221°F copper conductor. For current carrying capacity, wire size and circuit protector requirements, please refer to electrical data in this section. The power supply protection device can be a fuse or a "HACR" type circuit breaker.
 - High-voltage wires can pass through the tapping holes on the right, left or top of the device.
 - Two 7/8" and 1-23/64" diameter tapped holes can be used to connect high-voltage wires to the device.
 - The high-voltage wires must be connected to the red and black wires in the control part of the air handler.

4.2 Control Wiring



The low-voltage control line should not run in the conduit together with the high-voltage line. Keep the distance between the two catheters according to local codes.

-
- Scenes less than 100 feet in length should use 18 AWG colored low-voltage wires. 16 AWG wire should be used for scenes with a length of more than 100 feet.
 - See Figure 3.8 for the connection position of low-voltage wires.
 - For the correct wiring instructions, please refer to the wiring diagram located inside the air handler blower access panel.
 - After installation, make sure that the low-voltage and high-voltage wiring are kept separate.

4.3 Grounding



Danger: Electric shock

- The device must be permanently grounded. Otherwise, it will cause electric shock, personal injury or death.
-

- When installed according to existing electrical codes, grounding can be through wires or metal conductors.
- Grounding can also be achieved by connecting the grounding wire to the ground lug (ground lug) on the machine.
- When multiple power supply circuits are used, each circuit needs to be grounded plate separately.
- The grounding plate is located at the upper right of the cabinet.

4.4 Electrical Data

Table 4.1 Electrical data

Model	Voltage	Hertz	HP	Wind speed	Circuit AMPS	Maximum circuit protector
18K	208/230	60	1/3	5	0.8	5 (A)
24K	208/230	60	1/3	5	1.1	5 (A)
30K	208/230	60	1/2	5	1.3	5 (A)
36K	208/230	60	1/2	5	2.0	5 (A)

4.5 MCA/MOP data of electric heat kit

Table 4.3 Applicable heat kits for wall mount AHU installation

Heat kit model	AHU model	(kW) electric heat	MIN. Circuit Ampacity		MAX. Fuse or Breaker (HACR) Ampacity		Fan speed				
			230 VAC	208 VAC	230 VAC	208 VAC	1	2	3	4	5
			21-4223-01	18K	5	22.68	19.66	25	25	●	●
21-4223-02	7.5	34.04	29.50		40	35	×	×	●	●	●
21-4223-01	24K	5	22.68	19.66	25	25	●	●	●	●	●
21-4223-02		7.5	34.04	29.50	40	35	×	×	●	●	●
21-4223-03		10	45.37	39.32	55	45	×	×	●	●	●
21-4223-01	30K	5	22.68	19.66	25	25	●	●	●	●	●
21-4223-02		7.5	34.04	29.50	40	35	×	●	●	●	●
21-4223-03		10	45.37	39.32	55	45	×	×	●	●	●
21-4223-01	36K	5	22.68	19.66	25	25	●	●	●	●	●
21-4223-02		7.5	34.04	29.50	40	35	×	●	●	●	●
21-4223-03		10	45.37	39.32	55	45	×	×	●	●	●

- Heat kit applicable for wall mount AHU installation.
- Ampacities for MCA and Fuse/breaker including the blower motor
- The heat pump system needs specific airflow. Each ton of cooling requires 350 to 450 cubic feet (CFM) of air per minute, or nominally 400 CFM.

Table 4.4 Heater Kit Accessories

Model	Description	18K	24K	30K	36K
21-4223-01	5 kW heating kit, single-pole circuit breaker	●	●	●	●
21-4223-02	7.5 kW heating kit, single-pole circuit breaker	●	●	●	●
21-4223-03	10 kW heating kit, single/double pole circuit breaker	×	●	●	●

- indicates availability, and × indicates unavailability

5. Airflow performance

The air flow data is based on the cooling performance of coil and without filter screen. Performance table, select the appropriate product.

External static pressure ESP should be kept within the minimum and maximum limits shown in the following table to ensure the normal operation of cooling, heating and electric heating.

Table 5.1 Air flow performance

Model size of air processor	Motor speed		SCFM							
			External Static Pressure-Inch Water Column [kPa]							
			0[0]	0.1[.02]	0.2[.05]	0.3[.07]	0.4[.10]	0.5[.12]	0.6[.15]	
18K	Gear (5)	SCFM	917	898	853	821	789	761	730	
		Watts	179	182	189	195	200	205	210	
	Gear (4)	SCFM	872	837	804	770	737	709	679	
		Watts	156	161	165	171	176	181	186	
	Gear (3)-default high wind	SCFM	814	776	739	705	671	639	606	
		Watts	128	133	138	143	147	151	156	
	Gear (2)- Default low wind	SCFM	708	664	622	580	542	496	432	
		Watts	93	97	102	105	110	114	121	
	Gear (1)	SCFM	633	585	538	494	438	382	340	
		Watts	69	73	77	81	85	91	98	
	24K	Gear (5)- default high wind	SCFM	917	898	853	821	789	761	730
			Watts	179	182	189	195	200	205	210
Gear (4)- Default low wind		SCFM	872	837	804	770	737	709	679	
		Watts	156	161	165	171	176	181	186	
Gear (3)		SCFM	814	776	739	705	671	639	606	
		Watts	128	133	138	143	147	151	156	
Gear (2)		SCFM	708	664	622	580	542	496	432	
		Watts	93	97	102	105	110	114	121	
Gear (1)		SCFM	633	585	538	494	438	382	340	
		Watts	69	73	77	81	85	91	98	
30K		Gear (5)	SCFM	1318	1282	1241	1205	1165	1113	1071
			Watts	268	276	282	289	296	304	311
	Gear (4)- default high wind	SCFM	1230	1192	1151	1110	1055	1013	971	
		Watts	223	230	236	243	250	257	263	
	Gear (3)- Default low wind	SCFM	1129	1071	1025	976	933	886	840	
		Watts	172	178	184	191	197	203	209	
	Gear (2)	SCFM	1039	976	926	876	826	779	718	
		Watts	136	142	147	153	159	165	172	
	Gear (1)	SCFM	894	836	781	725	668	595	524	
		Watts	98	103	108	112	118	124	129	
	36K	Gear (5)- default high wind	SCFM	1318	1282	1241	1205	1165	1113	1071
			Watts	268	276	282	289	296	304	311
Gear (4)- Default low wind		SCFM	1230	1192	1151	1110	1055	1013	971	
		Watts	223	230	236	243	250	257	263	
Gear (3)		SCFM	1129	1071	1025	976	933	886	840	
		Watts	172	178	184	191	197	203	209	
Gear (2)		SCFM	1039	976	926	876	826	779	718	
		Watts	136	142	147	153	159	165	172	
Gear (1)		SCFM	894	836	781	725	668	595	524	
		Watts	98	103	108	112	118	124	129	

 The bold area indicates the airflow beyond the required range of 300-450cfm/ton.

Note:

1. The advanced airflow must be used as the rated airflow for the full-load operation of the unit.
2. The rated airflow of a system without an electric heater kit requires 300 to 450 cubic feet of air per minute (CFM).
3. The rated airflow of a system with an electric heater kit requires 350 to 450 cubic feet of air per minute (CFM).
4. The air distribution system has the greatest influence on air flow. Therefore, the contractor should only use the procedures recognized by the industry.

5. The design and construction of air duct should be done carefully. Poor design or process will lead to a significant decline in system performance.
6. The air supply duct should be set along the periphery of the air-conditioned space with appropriate size. Improper location or insufficient airflow may lead to insufficient ventilation or noise in the pipeline system.
7. The installer should balance the air distribution system to ensure that all rooms in the room have proper quiet airflow. The speedometer or airflow hood can be used to balance and verify the branch pipe and system airflow (CFM).

5.1 Indoor Fan Function

System Operation Function

Two-stage fan control

This model can be matched with a thermostat that supports two-stage fan control. When Y2 has a signal, the blower will run in high speed. When there is no signal in Y2 and there is a signal in Y1, the blower runs in low speed. When only G has a signal, the blower runs in low speed. When there is a signal in W1/W2, the blower runs in high speed.

This product supports five fan speeds. Please refer to the wiring diagram for wiring instructions.

If there is no thermostat supporting two-stage fan control, you can use one-stage fan control thermostat. Please refer to the wiring diagram for wiring instructions. If Y1 and Y2 are short-circuited, the blower only runs in high speed.

Anti-cooling fan delay

This function is realized by the T2 sensor of the indoor unit, which prevents the fan from being turned on before the indoor coil reaches a certain temperature. This function can prevent the unit from blowing cold air during heating.

1. When the dial code SW3-1 is set to "OFF" and the unit is in heating mode. The delay function of cold air blower will take effect according to the following entry conditions (all conditions must be met):
 - A, Indoor coil temperature (T2) < 82.4°F.
 - B. Electric heating off
2. If one of the following exit conditions is met, the unit will exit the anti-cold air function:
 - A.T2 >89.6°F
 - B. Electric heating on
 - C. The system is not running in heating mode.
3. In the heating mode, if one of the exit conditions of cold wind prevention is met, the unit will operate according to the set windshield.

Heating fan delay

If the dial code SW3-1 is set to "ON" and the machine is in heating mode, the fan will run for 90 seconds.

Passive Dehumidification Function (Optional)

This model has dehumidification function, which can make the blower run at low speed by DH signal sent by thermostat. This function needs to be supported by connecting an appropriate DH line from the indoor unit to the thermostat (with constant humidity function).



If the DH line is not connected, the equipment will still work normally.

6. Piping System

Field ductwork must comply with the National Fire Protection Association NFPA 90A, NFPA 90B and any applicable local ordinance.



Warning: Fire and carbon monoxide

- Under no circumstances should the return piping system be connected to any other heat-producing equipment, such as mantelpiece, stove, etc. Unauthorized use of such equipment may cause fire, carbon monoxide poisoning, explosion, personal injury or property damage.
-

Sheet metal ductwork run in unconditioned spaces must be insulated and covered with a vapor barrier. Fibrous ductwork may be used if constructed and installed in accordance with SMACNA Construction Standard on Fibrous Glass Ducts. Ductwork must comply with National Fire Protection Association as tested by U/L Standard 181 for Class I Air Ducts. Check local codes for requirements on ductwork and insulation.

- Duct system must be designed within the range of external static pressure the unit is designed to operate against. It is important that the system airflow be adequate. Make sure supply and return ductwork, grills, special filters, accessories, etc. are accounted for in total resistance. See airflow performance tables in this manual.
 - Design the duct system in accordance with “ACCA” Manual “D” Design for Residential Winter and Summer Air Conditioning and Equipment Selection. Latest editions are available from: “ACCA” Air Conditioning Contractors of America, 1513 16th Street, N.W., Washington, D.C. 20036. If duct system incorporates flexible air duct, be sure pressure drop information (straight length plus all turns) shown in “ACCA” Manual “D” is accounted for in system.
 - Supply plenum is attached to the 3/4” duct flanges supplied with the unit.
-



IMPORTANT: If an elbow is included in the plenum close to the unit, it must not be smaller than the dimensions of the supply duct flange on the unit.



IMPORTANT: If connected to the blower casing, the front flange on the return duct must not be screwed into the area where the power wiring is located. Drills or sharp screw points can damage insulation on wires located inside unit.

- Secure the supply and return ductwork to the unit flanges, using proper fasteners for the type of duct used and tape the duct-to-unit joint as required to prevent air leaks.

7. Refrigerant Pipe Connection

Before the refrigerant pipe connection is completed, keep the coil sealed. Please refer to the installation, operation and maintenance manual of the outdoor unit for detailed information on pipe size, pipe installation and charging amount.

Drain the system before charging the refrigerant.

Care should be taken to connect the refrigerant pipe so that it will not obstruct the maintenance channel in front of the equipment.

During brazing, nitrogen should flow through the refrigerant pipe.

Use a brazing shield to protect the paint of the cabinet, and use a wet rag to protect the rubber gasket and the piston sealing ring of the pipeline from being damaged by the torch flame. See Figure 7.1.

After the refrigerant pipeline connection is completed, seal and charge the surrounding gaps with pressure-sensitive gaskets.

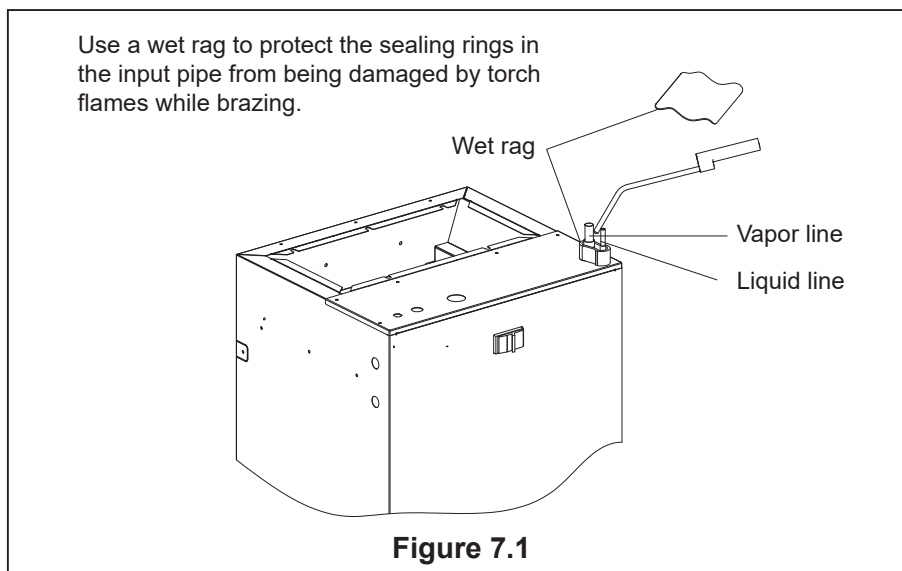

After brazing, make sure that there is no refrigerant leakage. After checking the vapor leakage, make sure that the pipeline is insulated, as shown in Figure 7.2.

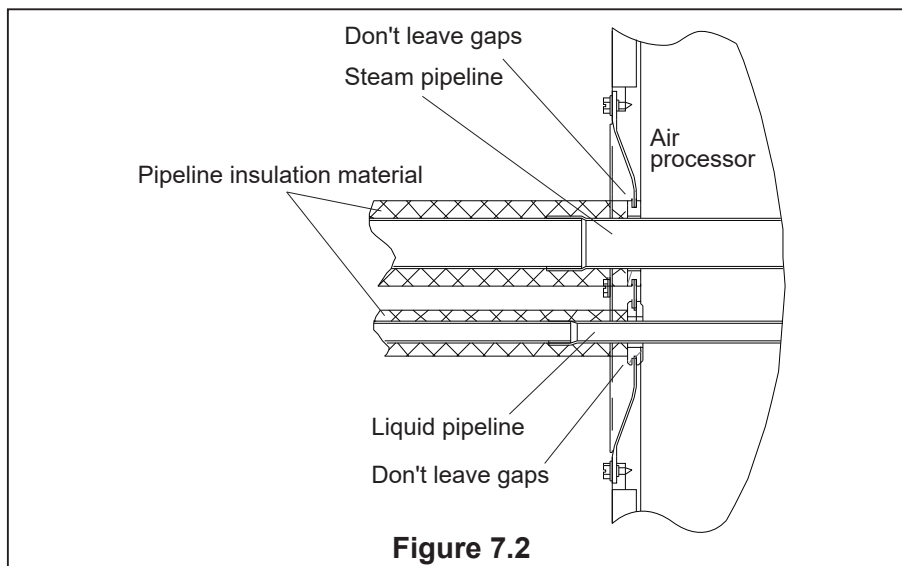

7.1 Condensate Drain Connection

The unit is supplied with primary and auxiliary condensate drains that have 3/4" NPT connections. Both drains must be trapped outside the unit and piped in accordance with applicable materials and building codes. Condensate should be piped to an open drain or to the outside.

For specific requirements, please consult local codes.

For the required condensate trap installation, please refer to Figure 7.3 and the following information.

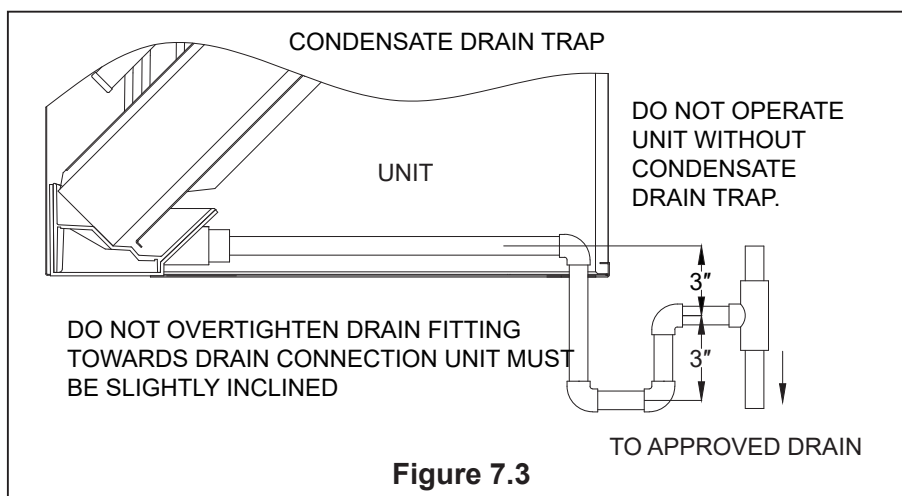

1. When connecting the drain connector to the drain pan, use a thin layer of PTFE paste, silicone or PTEF, and tighten it by hand.
2. When connecting the drain connector to the drain pan, don't over tighten it. Tight fittings will crack the pipe connection on the drain pan.
3. Important: If cleanout Tee is used, standpipe must be sealed/capped.



- Make sure that the drainage pipe will not block the inlet in front of the device. The minimum clearance required for removal and maintenance of filter screen, coil or fan is 24 inches.
- Make sure that the unit is placed horizontally or slightly inclined to the main drain outlet, so that water can be completely drained from the unit.
- Do not reduce the drain pipe size to less than the connection size provided on the condensate drain pan.
- All horizontal drainage pipes must be inclined downward at a slope of at least 1/8 inch per foot to ensure proper drainage.
- Do not connect the condensate drain line to the closed or open sewage pipe. Drain the condensate to an open drainage pipe or to a safe outdoor area.
- Where necessary, the drainage pipeline should be insulated to prevent damage caused by condensation water formed on the outer surface of the pipeline.
- If necessary, be prepared to disconnect and clean the main drainage pipe. Install a 3-inch elbow on the main drainage pipe as close as possible to the unit. Make sure that the top of the elbow is lower than the joint of the drain pan to allow the drain pan to drain completely (see Figure 7.3).
- Auxiliary drainage pipes should be extended to places where condensate can be easily seen. If the condensed water starts to flow out from the auxiliary drain pipe, the homeowner should pay attention to the possible problems.
- Plug the unused drain connector with the plug in the parts package provided with the equipment. Use a thin layer of Teflon paste, silicone or Teflon tape to form a waterproof seal.
- After installation, test the condensate drain pan and drain pipe. Pour water into the drain pan, enough to fill the drain traps and pipes. Check to ensure that the drain pan completely drains water, no leakage is found in the drain pipe fittings, and water is discharged from the main drain pipe terminal.

8. Air Filter (Not Factory Installed)

The filter is not included in the device and must be provided on site.

The size of external filters or other filtering devices must meet the maximum flow rate of 300ft/min, or meet the recommended value of filter type.

The application and placement of filter is very important for airflow, which may affect the performance of heating and cooling system. Reduced airflow will shorten the life of the main components of the system, such as motors, components, thermal relays, evaporator coils or compressors. Therefore, we recommend that the return air duct system has only one filter position. For systems without return air filter grids, multiple filter grids can be installed at each return air opening.

If a high-efficiency filter screen or electronic air filtration system is used, it is very important that the air flow rate is not reduced. If the air flow decreases, the overall performance and efficiency of the device will decrease. It is strongly recommended to contact professional installation technicians to ensure the correct installation of such filtration systems.



Do not double filter the return air system. Do not filter the air supply duct system. This will change the performance of the device and reduce the airflow.



Warning: Fire risk

- Do not operate the system without a filter. Part of the dust suspended in the air may temporarily stay on the duct and the air outlet of the room. Any circulating dust particles may be heated and burnt due to contact with AHU elements. This residue will stain the ceiling, walls, curtains, carpets and other items in the house. When some types of candles, oil lamps or igniters burn, soot may be generated in the filter.
-

9. Installation Size of Filter Screen

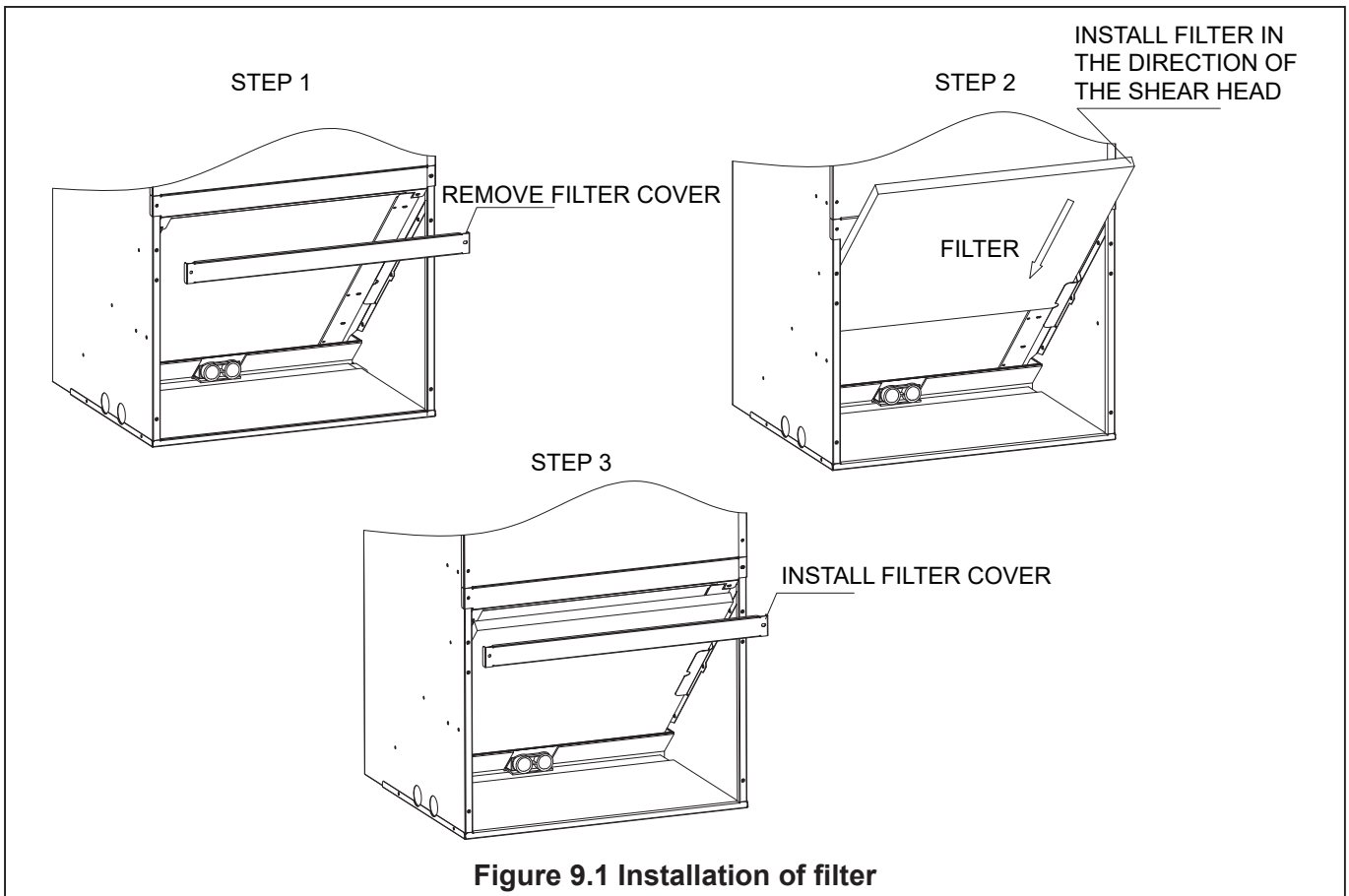

Figure 9.1 Installation of filter



The filter is not included in the device and must be provided on site.

Table 9.1 Size number

Model	Filter size inches[mm]
18K/24K	16X20[406X508]
30K/36K	20X20[508X508]

Removal/Installation of Air Filter

- Manually remove the bolts and remove the filter cover, as shown in Figure 9.1.
- Hold the edge of the strainer and pull it out.
- If a reusable filter is used, please clean it according to the manufacturer's specifications before re-installing it.

10. Maintenance



In order to keep high performance and minimize possible equipment failures, the equipment must be regularly maintained.

10.1 Cleaning Precautions



Warning:

- Any equipment maintenance can only be carried out by qualified maintenance personnel.
-



Warning: Before cleaning and maintenance

- Before cleaning or maintenance, be sure to turn off the equipment and disconnect its power supply.
-



Be careful:

- When removing the filter, do not touch the metal parts in the device. Sharp metal edges can cut you.
-



Note:

- Do not use chemicals or chemically treated cloth to clean the equipment.
 - Do not use benzene, paint thinner, polishing powder or other solvents to clean this machine.
 - Do not operate the system without a filter
-

10.2 Routine Maintenance

Your equipment must be inspected regularly by qualified service technicians. Your annual system check must include:

1. Check the filter every 90 days, or at any time as needed. If it is blocked or block, please clean or replace it immediately.
2. Inspection and/or cleaning of impeller housing and motor.
3. Check and clean indoor and outdoor coils as needed.
4. Check and/or clean indoor coil drain pan and drain pipe and auxiliary drain pan and pipe.
5. Check all wires and connections. Refer to the wiring diagram and make corrections as needed.

11. Wiring Diagram



Warning: Electric shock

- Before repairing or installing this device, please disconnect all power supplies. There may be multiple power sources. Otherwise, property damage, personal injury or death may result.
-



Danger: Electric shock

- The device must be properly grounded and protected by a circuit breaker or fuse.
-



Warning: Electric shock

- These devices must be wired and installed according to all national and local safety codes.
-

- To avoid electric shock, make sure:
 - 1) Equipment is properly grounded.
 - 2) The main power plug of the device has been connected to the ground wire (do not change it).
 - Do not tighten the power cord.
-



The dotted line in the following thermostat wiring diagram indicates optional wiring (wiring for passive dehumidification function and/or electric heating). For the wiring of the thermostat, please refer to the user manual of the thermostat.



Dh wiring is optional and requires a thermostat with a humidifier. Dh plays the role of passive dehumidification, and puts the indoor blower in the Low fan speed. If Dh wiring is missing, the system will run in the normal operation sequence.

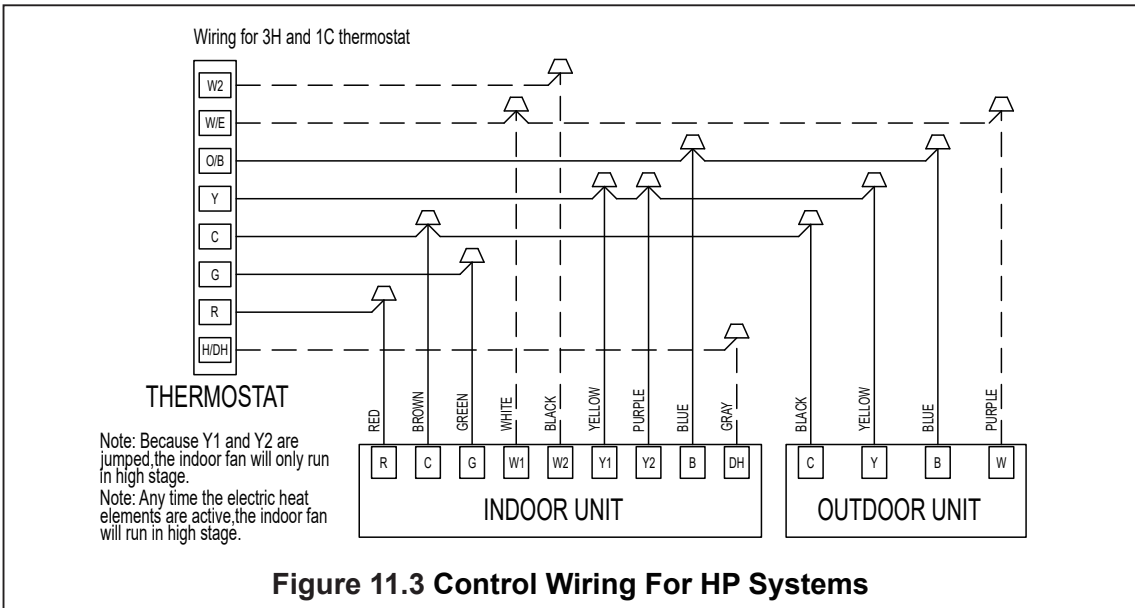
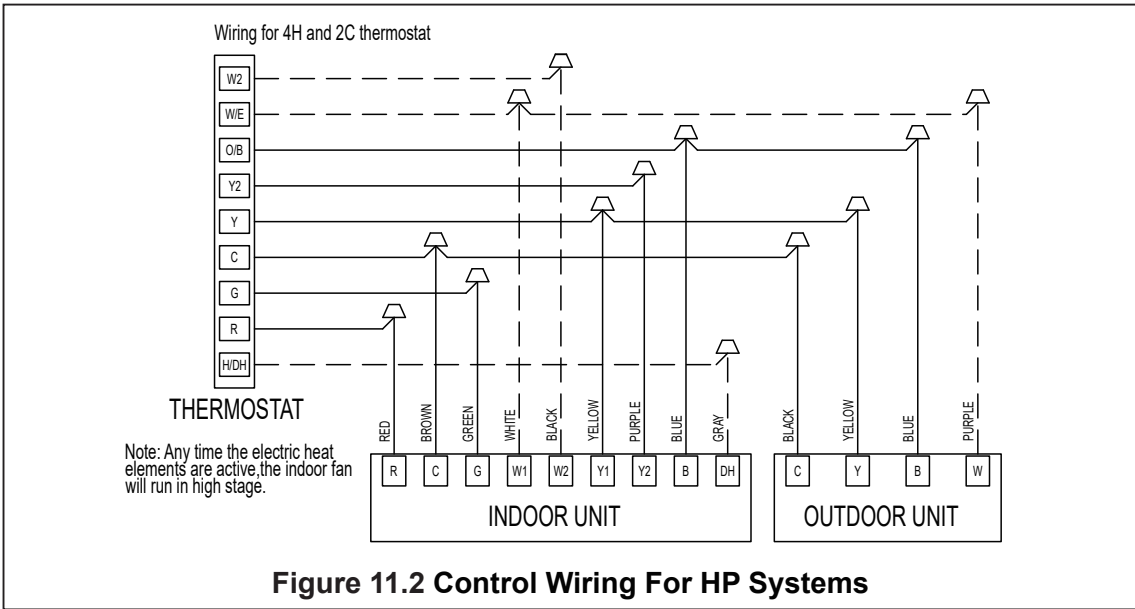
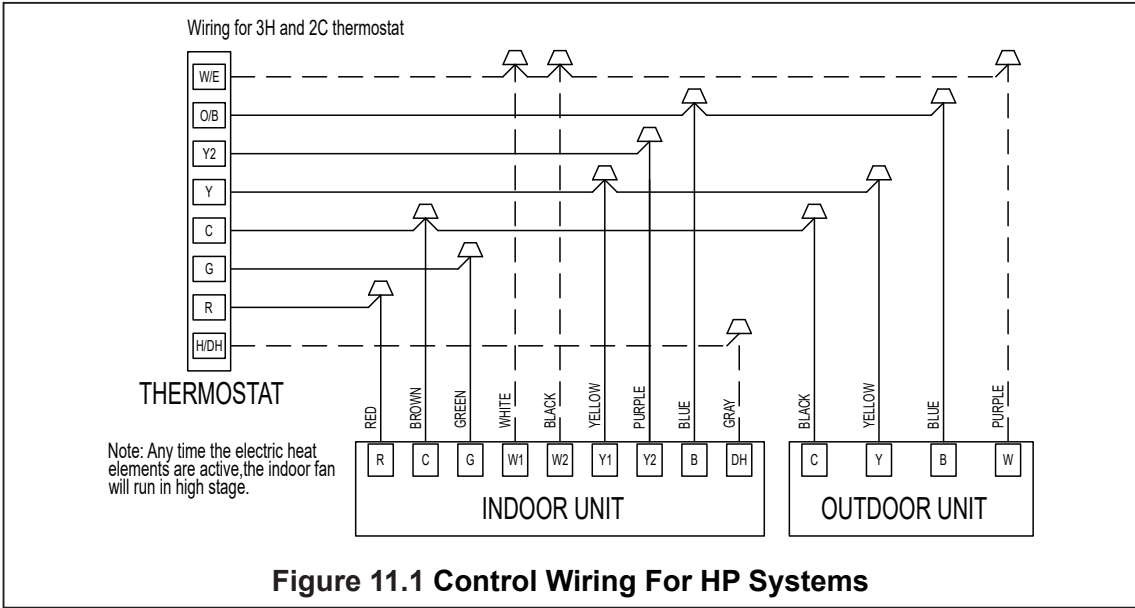

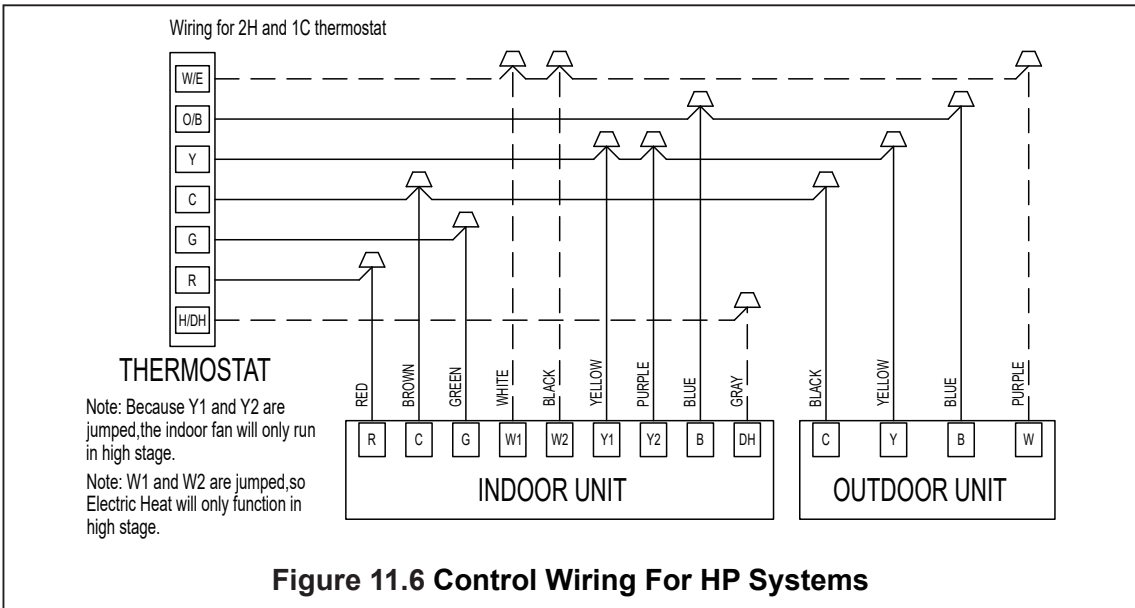
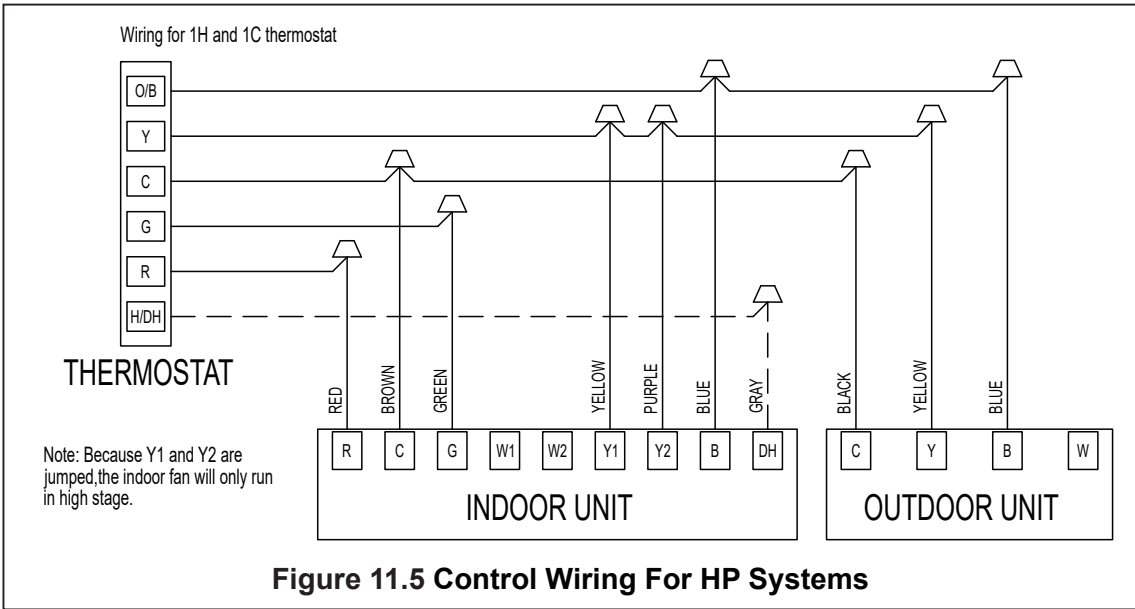
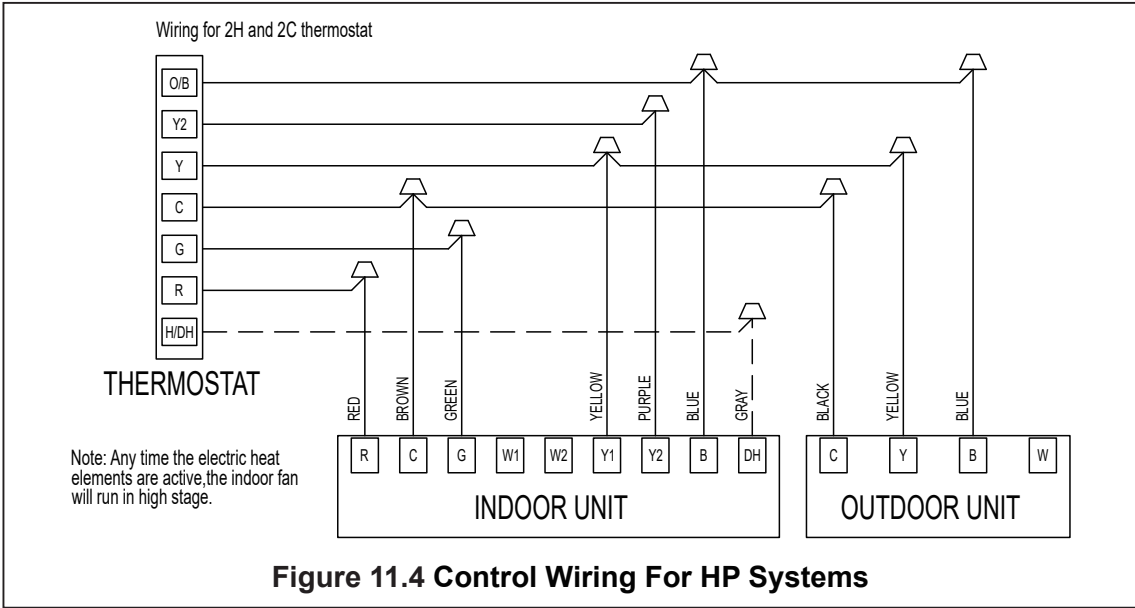

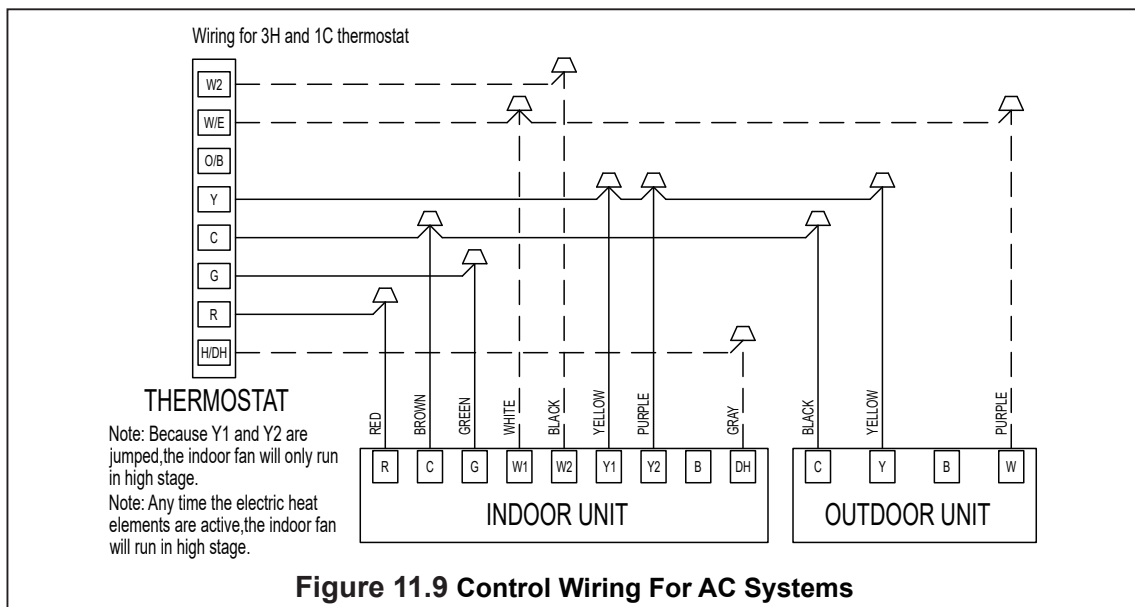
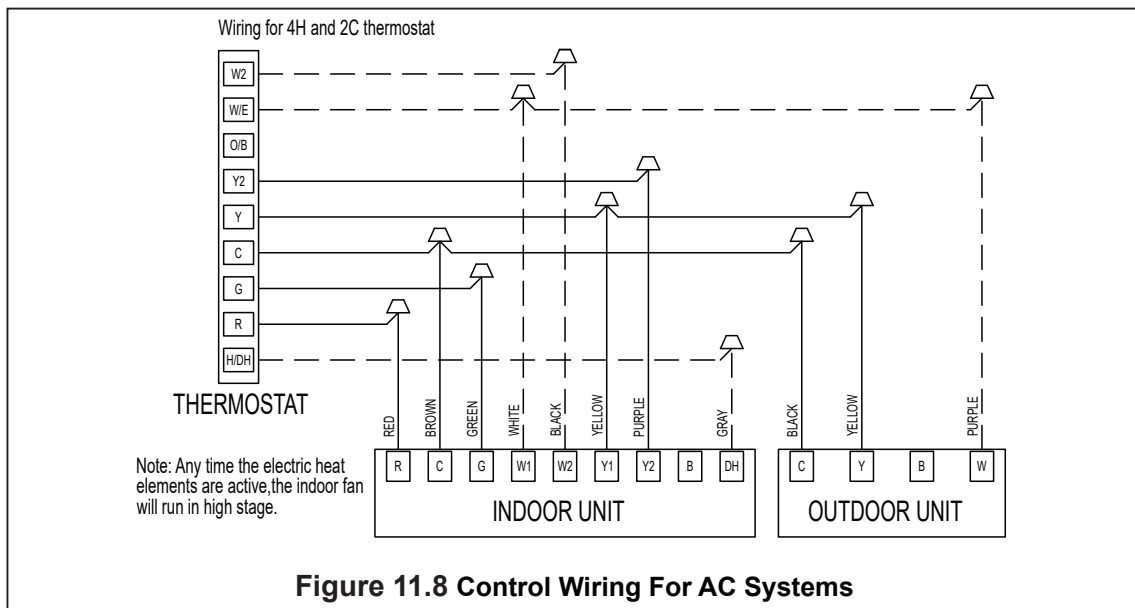
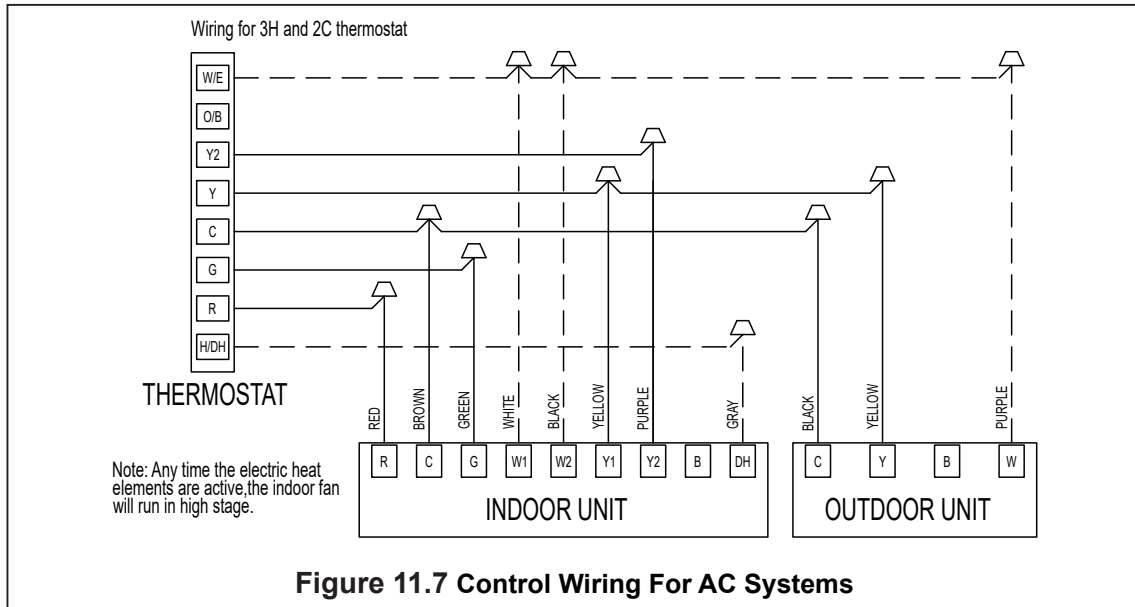

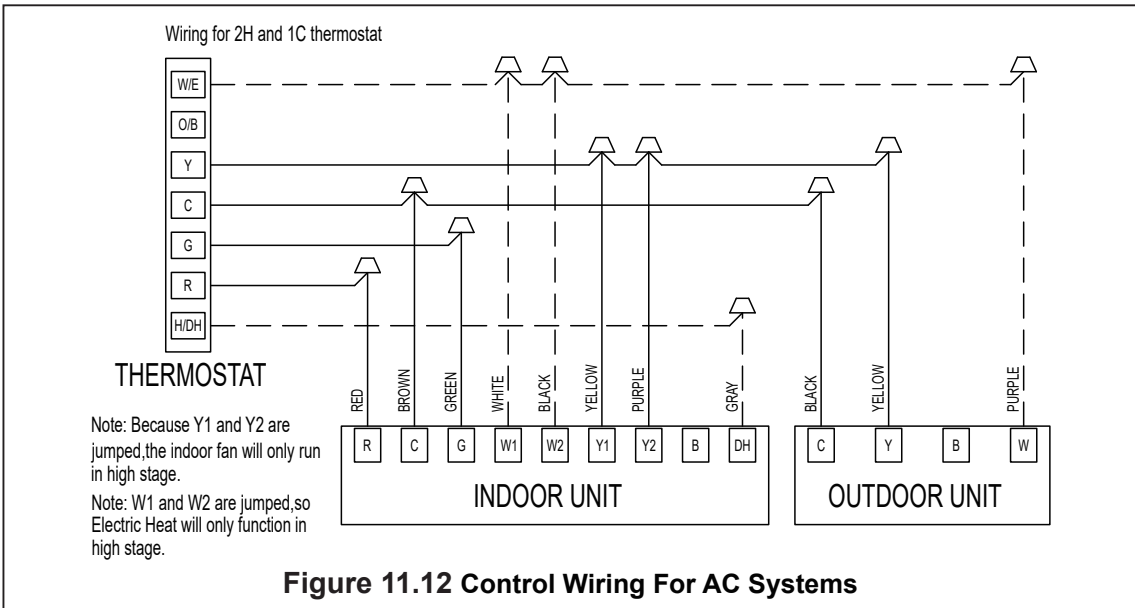
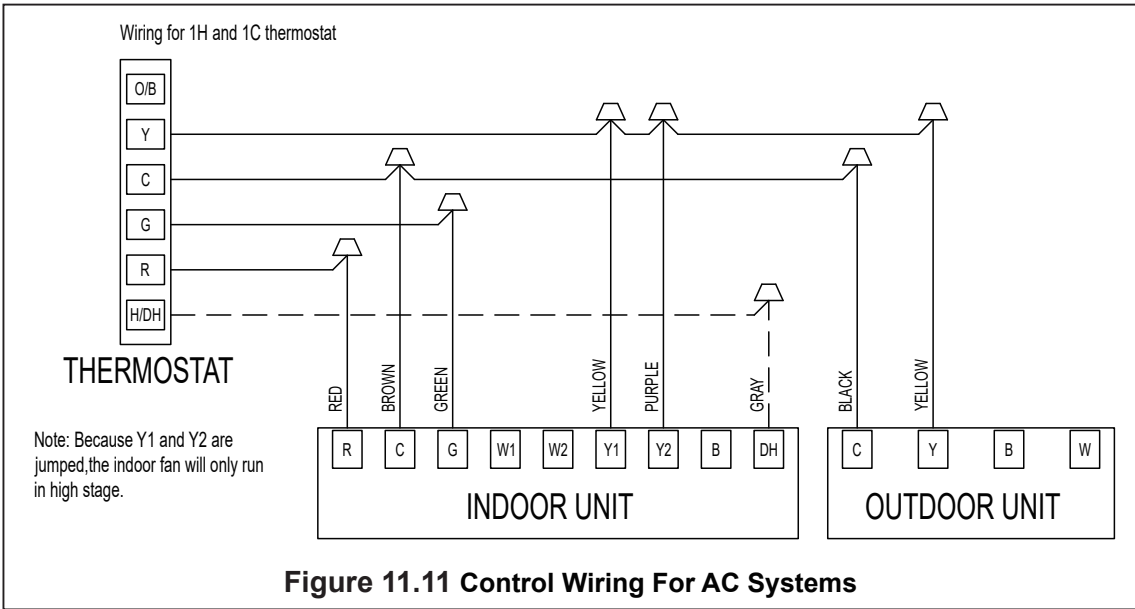
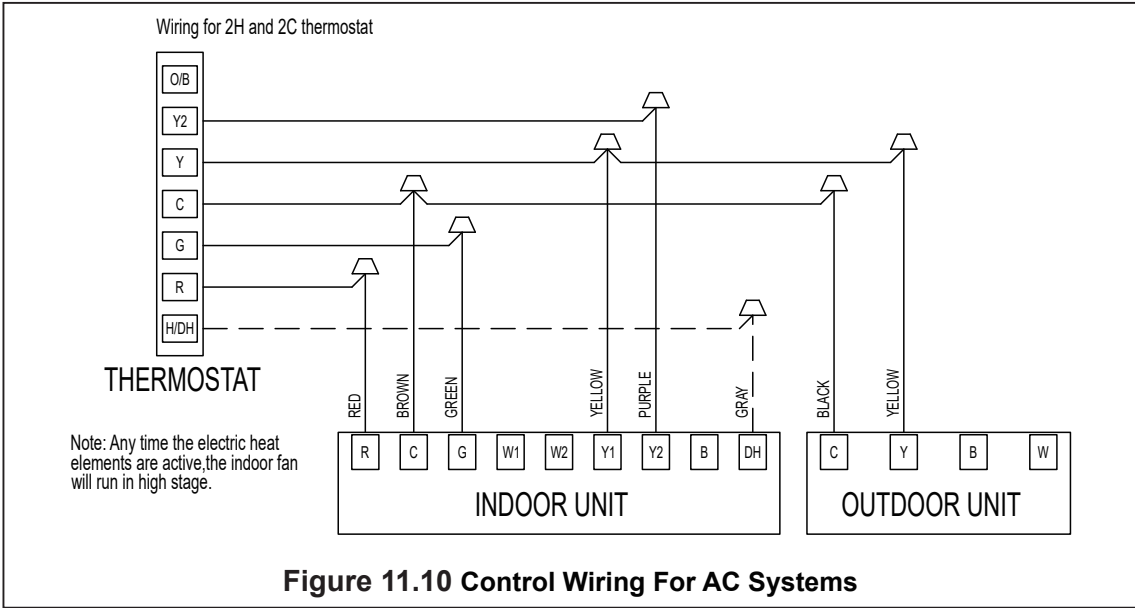
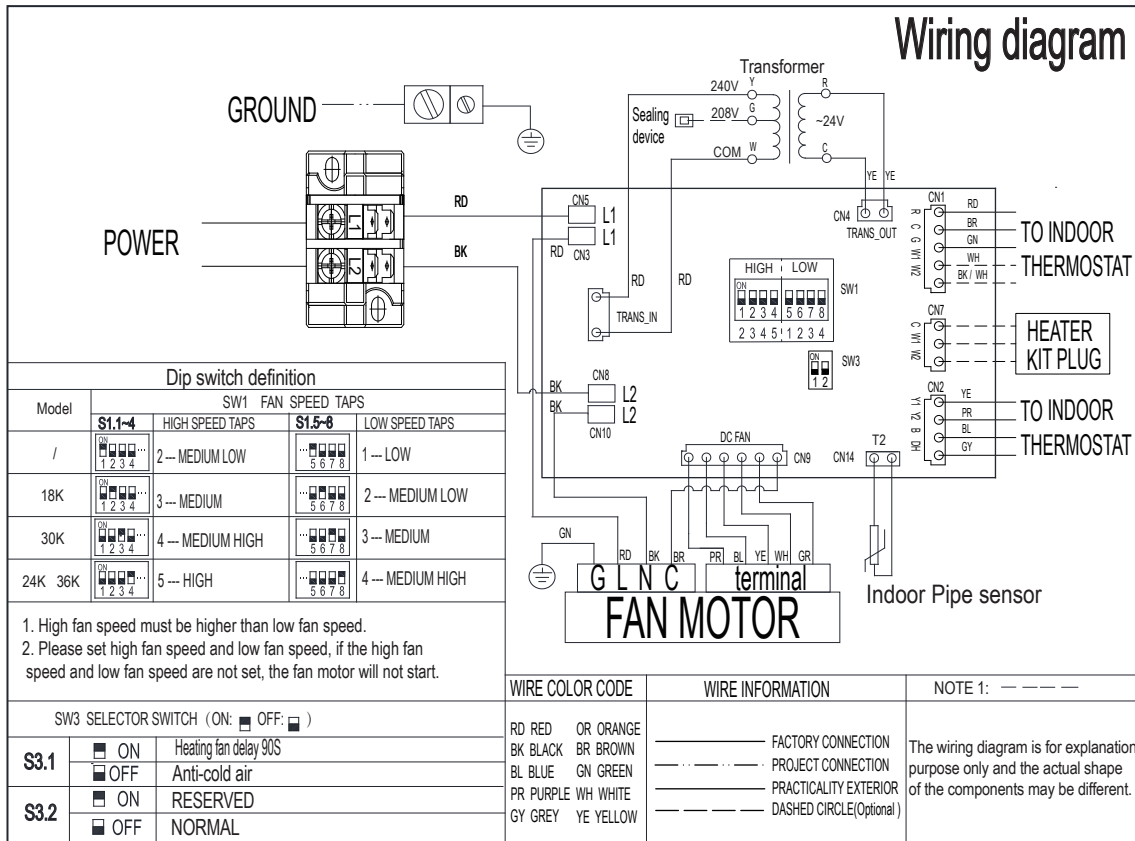

Table 11.1 Wire gauge of high voltage system

Type (Btu/ hour)		18K	24K	30K	36K	
Power	Stage	Single				
	Voltage/frequency	208/230VAC, 60 Hz				
Wire gauge	Indoor unit power cord	Line quantity	3	3	3	3
		Wire diameter (AWG)	16	16	16	16
	Outdoor unit power cord	Line quantity	3	3	3	3
		Wire diameter (AWG)	14	14	12	12



Applicable to 18K/24K/30K/36K

NOTE: For reference only, the actual wiring diagram shall prevail

SMSA-V-ENG01.V1
802035000083

Design, material, performance specifications and components
subject to change without notice.