

SharkBite® Washing Machine Boxes

DESCRIPTION

The SharkBite Washing Machine Outlet Box is integrated with SharkBite ends to allow for quick & easy installation in residential laundry spaces. The SharkBite Washing Machine Boxes can be used on Copper, CPVC, PEX, and PE-RT.

FEATURES AND BENEFITS

- Instant push-fit connection for increased ease-of use:
No soldering, clamps, unions, or glue required.
- Fittings certified to 200 PSI Max and 200°F Max (93°C):
Proven durability and quality.
- Fits copper tubing, CTS CPVC, PEX and PE-RT pipe:
Connects all four types in any combination.
- Integral tube liner for PEX installations:
Means no loose components and ensures a secure, reliable connection.
- Optional integral water hammer arrestors for water shock wave prevention
- Multiple valve and drain options for remodel and new construction applications
- Designed and certified to ASSE 1061, ASME A112.18.1/CSA B125.1, NSF/ANSI 61, and NSF/ANSI 372 product standards:
Quality engineered and manufactured

SPECIFICATION

The tube shall be inserted into the SharkBite® push-fit fitting in the first stage through a release collar and then through a stainless steel grab ring. The grab ring has teeth that open out and grip onto the tube. At the second stage the tube shall be pushed through an O-ring protector which aligns the tube. A specially formulated EPDM O-ring shall be compressed between the wall of the fitting and the tube before the end of the tube reaches the tube stop. Only when the tube has passed through the O-ring and reached the tube stop shall a secure joint be created. The fitting shall be a SharkBite® push-fit fitting.

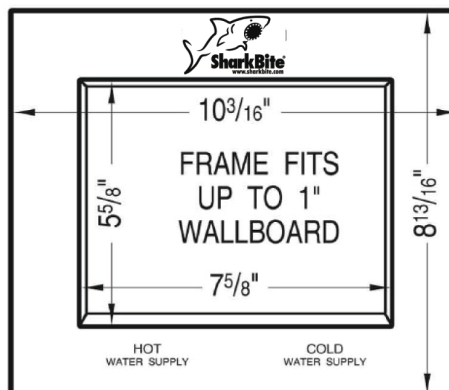
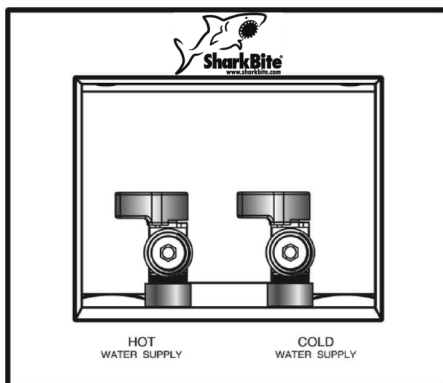

SharkBite® Washing Machine Boxes

TYPICAL INSTALLATION

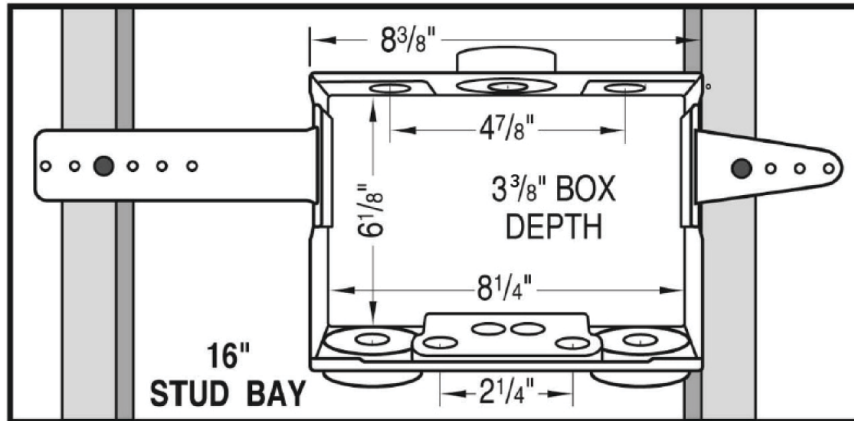

SKU	Description
24763	Washing Machine Kit RT Packaging
25031	Washing Machine Kit RT Packaging with Arresters
25098	Washing Machine Kit WP Packaging
25099	Washing Machine Kit WP Packaging with Arresters

SPECIFICATION DATA

Performance:

Maximum Working Pressure 200 PSI
 Maximum Temperature 200°F
 Service Potable water

Materials:

Body Lead Free DZR Brass
 O-ring EPDM
 Grab Ring Stainless Steel Grade 316
 Tube Support Liner Polysulfone

CERTIFICATIONS

The SharkBite® push-fit fittings have been designed, certified and listed to ASSE 1061, ASME A112.18.1/CSA B125.1, NSF/ANSI 61, and NSF/ANSI 372. The SharkBite® push-fit fittings are listed by IAPMO and are certified for potable and hydronic heating water distribution (note: Glycol mixture for hydronics is allowable up to a 100% concentration). The SharkBite® push-fit fittings have been certified for underground applications as a manufactured joint without access panels and they meet UPC, IPC and cUPC requirements. The SharkBite push-fit fittings can be used with the following materials: PEX tubing complying with ASTM F 876 or CSA B137.5, copper tubing hard drawn Type K, L and M and annealed Type M not to exceed 3/8" nominal, complying with ASTM B88, CPVC tubing complying with ASTM D 2846 or CSA B137.6, and PE-RT pipe complying with ASTM F 2769.