

Model 763 Ventilation Fan with Light

DESCRIPTION

- Efficient ventilation and bright light in one easy installation.
- Fan and light operate separately or together.
- Quiet operation with one-piece molded blower wheel and silent backdraft damper.
- Attractive grille styling.
- Plug-in motor and light.
- Uses one (1) 100 watt incandescent bulb (bulb not included).
- Refer to NuTone's catalog for a complete listing of accessories to effectively adapt this Ventilation Fan with Light to your construction requirements.

DESIGN FEATURES

- Air Delivery:** 50 cfm.
Sound Level: 2.5 Sones.
Dimensions: **Housing:** 8¼" x 8" x 5¾".
Grille: 12" x 10¾".
Lamp: One 100W maximum A19 (bulb not included)
- Material & Component Data:** **Housing:** Galvanized steel.
Grille: White polymeric.
Lens: Translucent white polymeric.
Reflector: Galvanized steel (white).
Damper: Polymeric.
- Motor:** Plug-in, permanently lubricated.
Electrical Rating: With one (1) 100 watt bulb:
 120 VAC, 60 Hz, 1.6 A
Blower Wheel: One-piece polymeric,
 4¾" diameter.
Duct Size: 4" diameter.
Mounting: Mounting flange provided.
- Model 763H:** Housing Pack
Model 763F: Finish Pack

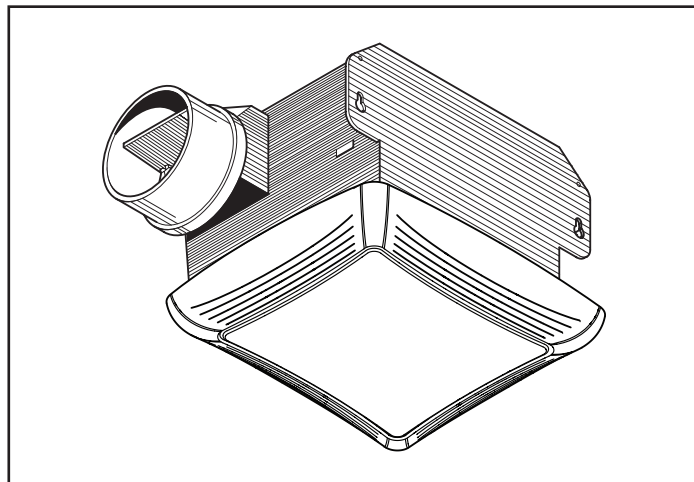

INSTALLATION

- Suitable for use over tub or shower enclosure when installed in a GFCI protected branch circuit.
- Installation instructions are included with each unit.
- Type IC for use with thermal insulation.
- Not for use with solid state speed controls.
- Not for use in kitchens.

ARCHITECT'S SPECIFICATIONS

Ventilation Fan with Light shall be NuTone Model 763 as manufactured according to listed specifications. Fan shall ventilate 50 cfm at a sound level of 2.5 Sones. Housing shall be 8¼" x 8" x 5¾" and connect to 4" duct.



Broan Hartford, Wisconsin www.nutone.com 888-336-3948

REFERENCE	QTY.	REMARKS	Project
			Location
			Architect
			Engineer
			Contractor
			Submitted by Date

PERFORMANCE RATINGS

MODEL 763 FAN / LIGHT

HVI PERFORMANCE

Model	Static Pressure (Ps)	CFM	Sones
763	0.10	50	2.5
	0.25	29	



HVI-2100 CERTIFIED RATINGS comply with new testing technologies and procedures prescribed by the Home Ventilating Institute, for off-the-shelf products, as they are available to consumers. Product performance is rated at 0.1 in. static pressure, based on tests conducted in a state-of-the-art test laboratory. Sones are a measure of humanly-perceived loudness, based on laboratory measurements.

AMPS

Model	Amps
763	1.6

WEIGHT

Model	Shipping Weight
763	6.0 lbs.

AIR FLOW PERFORMANCE

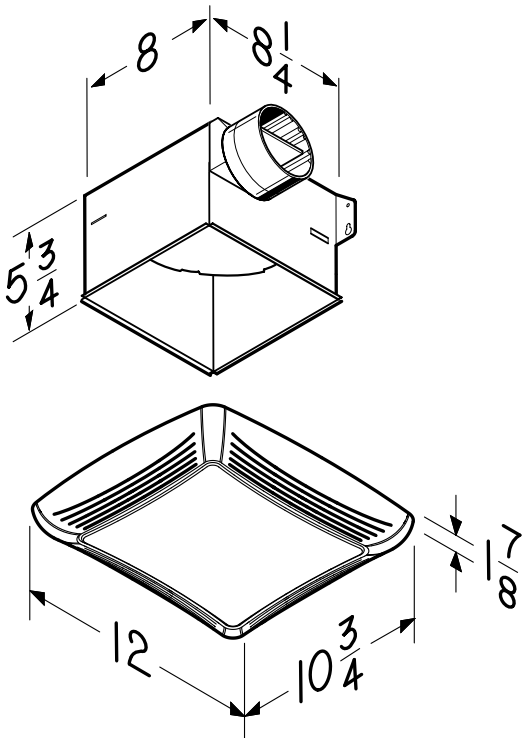
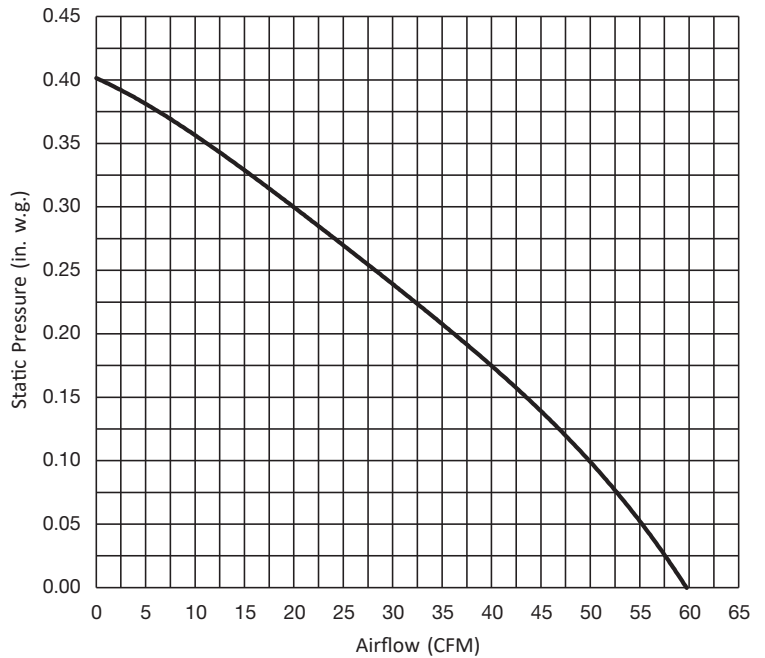

NuTone

Broan Hartford, Wisconsin www.nutone.com 888-336-3948